



Features

- Pass-Through Construction
- 36" Powered Carton Magazine
- Interlocked Barrier Guarding
- Adjustable Flighted Infeed
- Pressurized Hot Melt System
- Elevated Frame For Sanitation
- 3 Head Rotary Erector
- Programmable Limit Switches
- Casters and Leveling Legs
- Detent Jam Protection Clutch
- Cartons Carrier Flight Chain
- 3 HP AC Inverted Drive Motor
- Up To 600 Carton per Minute
- Optional Laser Coding Systems
- Optional Coupon Placement
- Option Extended Magazines

Design
Machine & Manufacturing



www.designmachinemfg.com

Wash-Down Series Available

CHA-3

**Continuous Motion
Automatic Cartoner**

Packaging with Performance

Specifications

Carton Range (LWD)

Minimum: 1 x 3/4 x 5-1/4
Maximum: 10.25 x 5 x 12

Packaging Material

SBS, SUS, Clay Coat News Chipboard

Package Type

Straight & Reverse Tuck
Glue End Seal

Main Voltage

240VAC-3 Phase-60 Hz
480VAC-3 Phase-60 Hz (Optional)

Control Voltage

24VDC (Optional 120VAC)

Speed Range-Maximum

12.0" Pitch 140 Cartons Per Minute
10.5" Pitch 180 Cartons Per Minute
9.0" Pitch 240 Cartons Per Minute
6.0" Pitch 350 Cartons Per Minute
4.5" Pitch 400 Cartons Per Minute

Air Consumption

6 CFM @ 80 PSI

Floor Space

76.5" Width (1943mm)
198" Length (5030mm)

Floor Plan

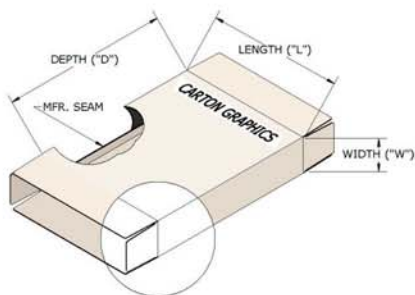
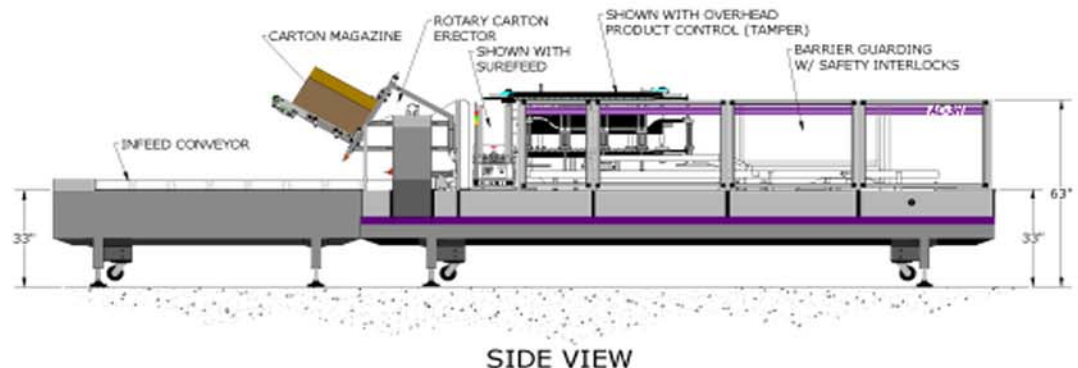
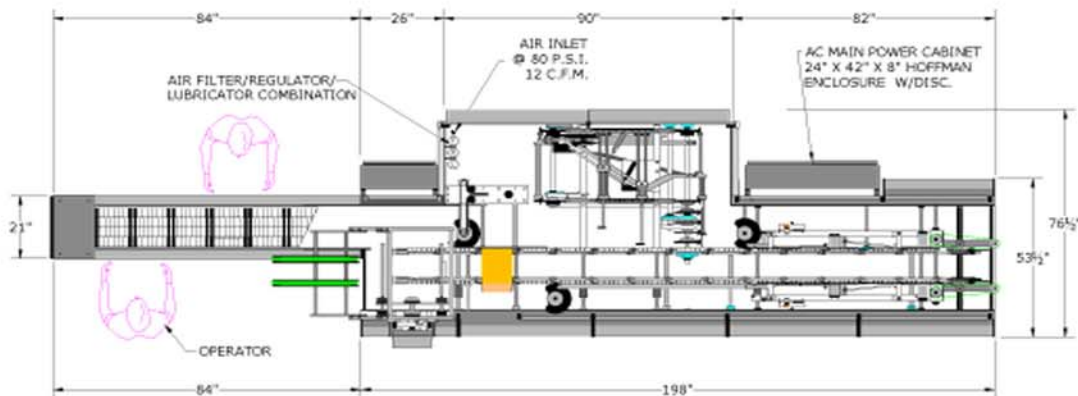

With a variety of attachments, The CHA-3 can be fitted to accommodate many styles of containers. With Heavy-Duty line shafting and variable speed drives the machine can be adjusted to fit any line speed. All materials contacting the cartons and product are FDA and USDA approved materials. Main drive is protected with an adjustable detented overload clutch that protects the system from damage in the event of a jam. Other items include high capacity carton magazine, elevated frame for sanitation, heavy-duty carton and product flight chains, efficient dynamic box runner technology and perimeter barrier guarding to mention just a few.

Sales Representative

Factory Information

Design Machine & Manufacturing
2491 Simpson Street
Kingsburg, California 93631
P (559) 897-7374
info@design-serve.com
www.designmachinemfg.com